

BIRD WEIGHING SYSTEM

Type DWS-20

OPTICON®

is a registered trademark of
H&F Electronics B.V.
 Rijnaakkade 5, 5928 PT
 Venlo - The Netherlands
 P.O. Box 3164, 5902 RD
 Venlo - The Netherlands
 Phone nr. 00-31-77 - 323 12 00
 Fax nr. 00-31-77 - 387 33 06
 E-mail: info@opticon-agri.com
 www.opticon-agri.com

No rights can be derived from the text, photos and drawings in this brochure.

Description

The OPTICON DWS-20 is a management system designed for the modern producer who requires optimum production information. The DWS-20 unit incorporates a bird weighing system, temperature recording, water and feed consumption registration and alarming for four poultry houses.

Bird weighing

The system measures and records the live body weight of the birds. To be used for broilers, breeders, rearing (in cages), ducks and turkeys. The weighing scale is suspended at the ceiling. This generates a large number of weighings with high level of accuracy. The DWS-20 shows you at a glance whether the planned target weight agrees with the actual bird weight in any house. It also alerts you when an abnormal growth rate fluctuation is detected.



Central display unit for 4 barns



Broiler scale

Further the DWS-20 shows the age of the birds, the actual average weight, the gain for the last 24 hours, the target weight, the difference between the actual and the target weight, the number of weighings, the standard deviation, the coefficient of variation (CV) and the uniformity. Target weights are pre-programmed for all major breeds like Cobb, Ross, BUT, Nicholas etc.

Temperature recording

The temperature will automatically be monitored. This is valuable to see in relation to bodyweight and water feed consumption.

OPTICON®

Water- and feed consumption

To analyse the performance of the flock, it is essential to keep track of the water and feed consumption. Stocking number and mortality are also important.

All the above mentioned figures are stored and retrievable for the last 50 days.

To visualise all figures in a graphical way, it is possible to connect the DWS-20 to a local PC or via a MODEM to a remote location.



How do you want to weigh these turkeys manually ?

Original features

The weighing scales are suspended. Thus there is no physical contact with the litter. There is no wire on the floor which can be destroyed by the birds or ammonia. The large surface of the scales allows easy access for the birds which results into a large number of weighings. The scale is not inhibited even when there are several birds constant occupying the scale. Automatic detection of males and females when in use for breeders. Large number of weighings/day, even with heavy birds at the end of the flock period.



Many birds can be on the platform at the same time

For rearing layers in cages, there is a perch that is used as a weighing device. The unique combination to have a live bird weighing system in combination with temperature and water - feed consumption in one unit is striking.



Breeders with male/female selection

OPTICON DWS-20 IN- AND OUTPUTS

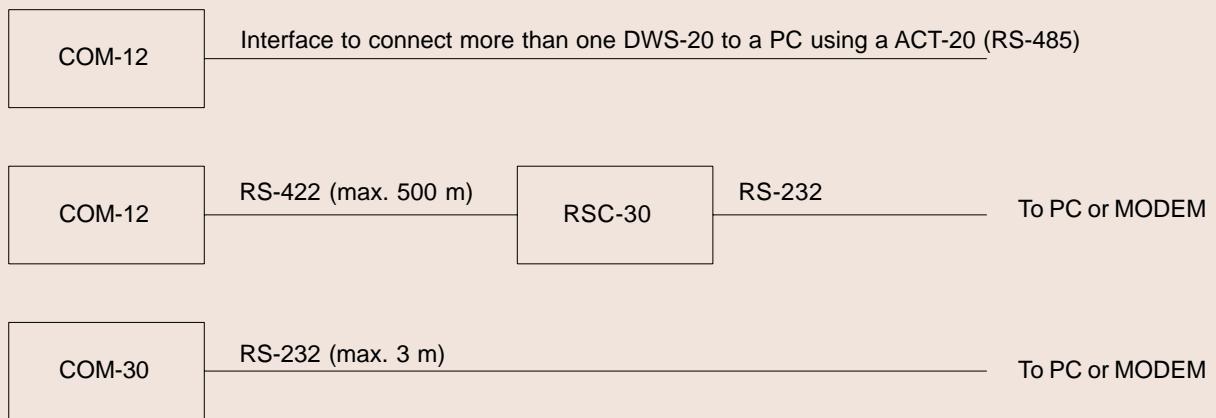
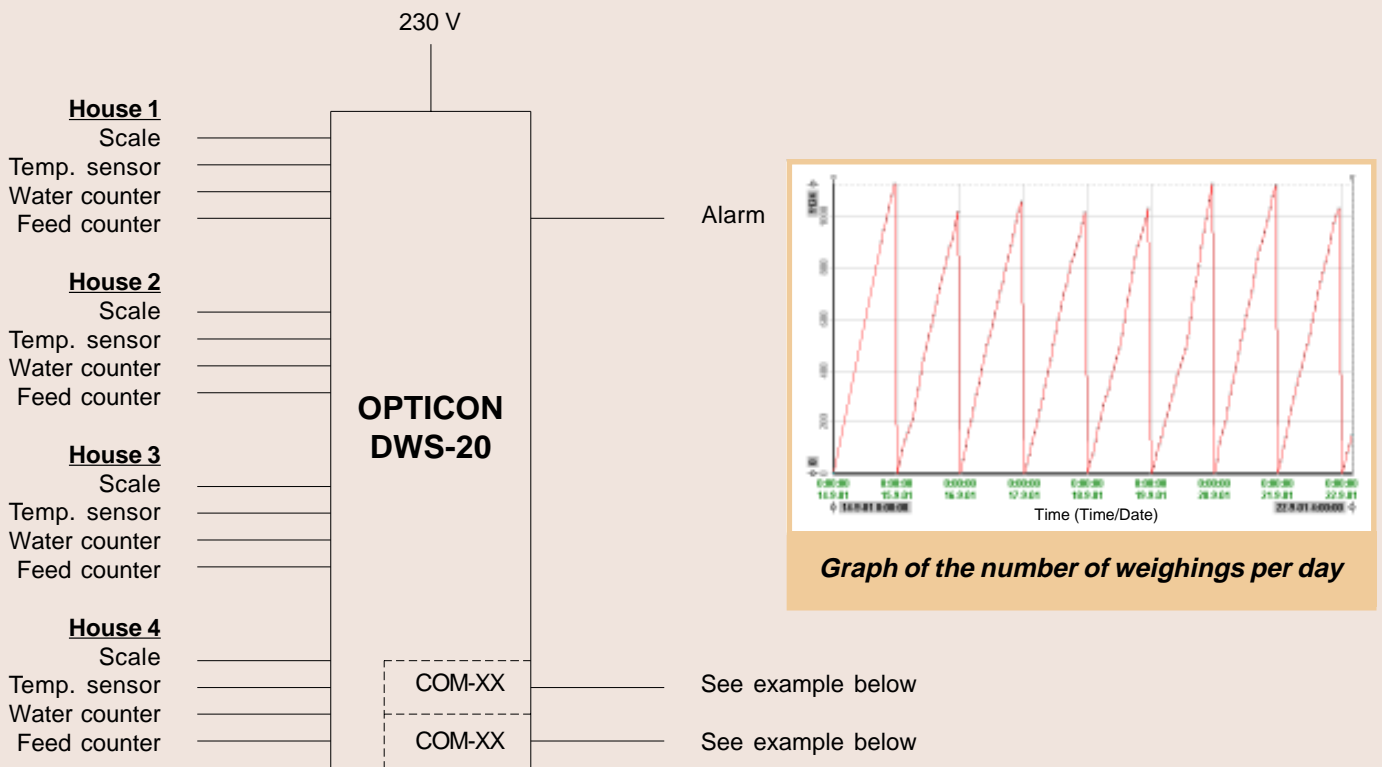

ADVANTAGES FOR THE USER

- Much better, faster and more flock information for management purpose.
- A large number of weighings per day without stress for the birds as well as for the farmer.
- System is suitable for all kinds of birds.
- Monitors the body weight, environment and water - feed consumption.
- Gives better control of the production, increase productivity.
- Number of weighings/day gives a good indication of the activity of the birds.
- Early detection of disease (reduction of weighings or growth).
- Controls the quality of a new batch of feed.
- Slaughter weight can be obtained much more accurate, within < 1,5 %, which results in a better planning for the slaughterhouses.
- Avoids financial penalizes for inaccurate weights.
- By using the system for rearing and breeding, better tuning for feed rationing possible.
- No manual weighings needed anymore, which saves time.
- No maintenance because the cable and the electronic parts are not in contact with the litter and the birds, no moving mechanical parts.



Automatic bird weighing in use with rearing laying hens in cages

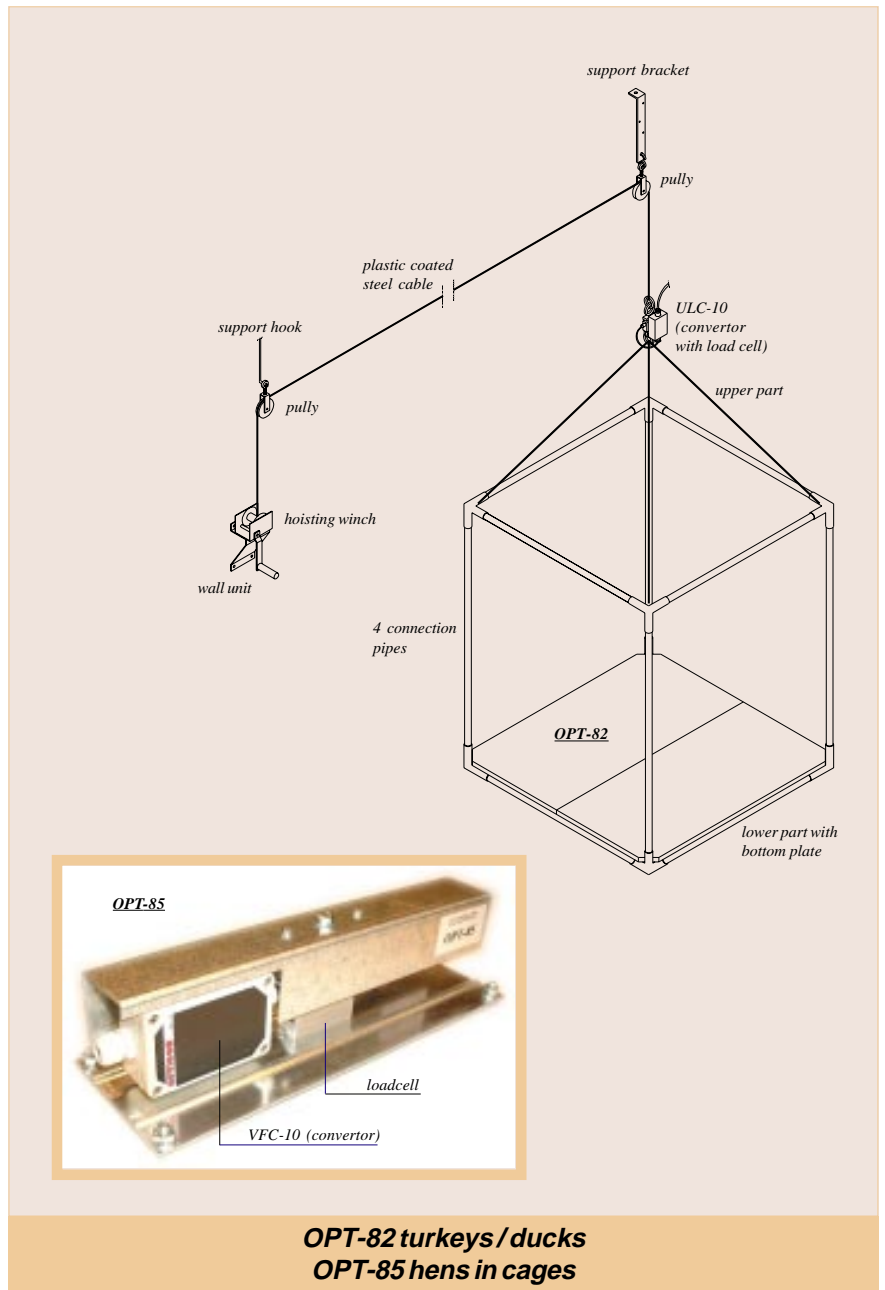
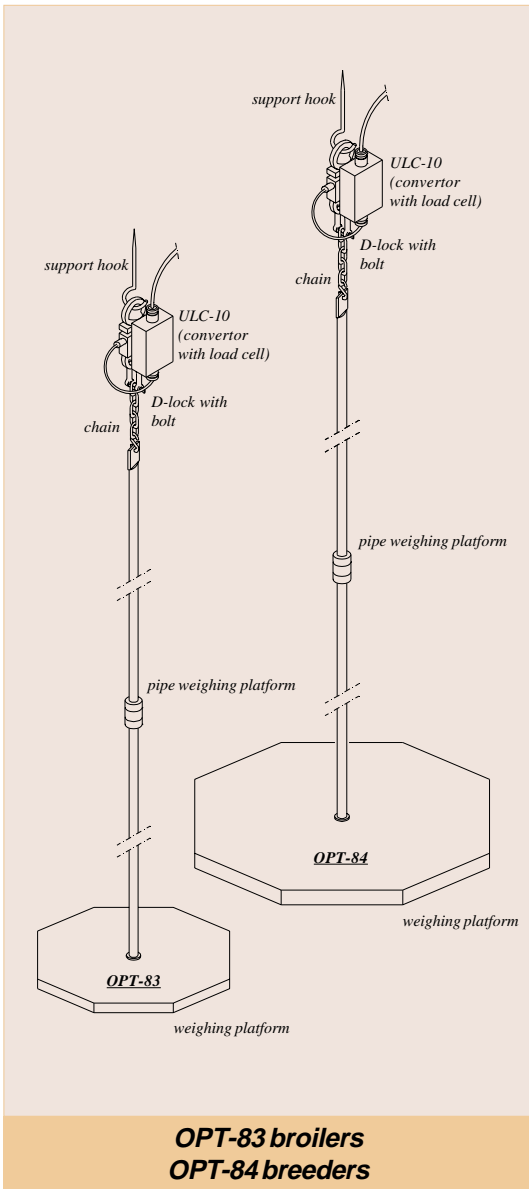

Your dealer:

Ruby 360
INTEGRATED AGRICULTURAL SOLUTIONS

1-888-218-7829 sales@ruby360.ca

40 Woodstock St. N., Tavistock, ON N0B 2R0

ruby360.ca

OPTIGON®